

15.6" Fanless Multi-touch Panel PC with Intel® Celeron™ J1900 Processor



## Features

- 15.6" TFT XGA LED Panel with Projected Capacitive Touch Display
- True Flat Front Panel
- IP54 Resolution: 1366 x 768
- Two-finger Touch Control while Wearing Gloves
- Internal SATA 2.5" HDD and mSATA
- Socket Panel and VESA Mounting

## Applications

- Human Machine Interface (HMI)
- Factory / Manufacturing Automation
- ATM / Self-service / Kiosk
- Applications Vending Machine / Ticketing Machine

## Packing List

Description
1 x GSR-152PW
1 x Driver CD
1 x Power Adapter
1 x Panel Mounting Screws

## Optional Items

Part No.	Description
AWD-WF001	wifi 802.11 b/g/n (1T1R) + 1 antenna , Half size
AWD-WF002	wifi 802.11 b/g/n + BT4.0(1T1R) +2 antennas (dual band), Half size
AWD-WF003	wifi 802.11 a/b/g/n/ac/BT4.0 (2T2R) + 2 antenna (dual band), Half, size
ACS-100-STD	VESA Table Stand

## Ordering Information

Part No.	Description
GSR-152PW-A1	15.6" 16:9 LCD (1366 x 768), Fanless Panel PC with Intel® Celeron J1900 2.0GHz CPU, Projected Capacitive Touch

## Dimensions

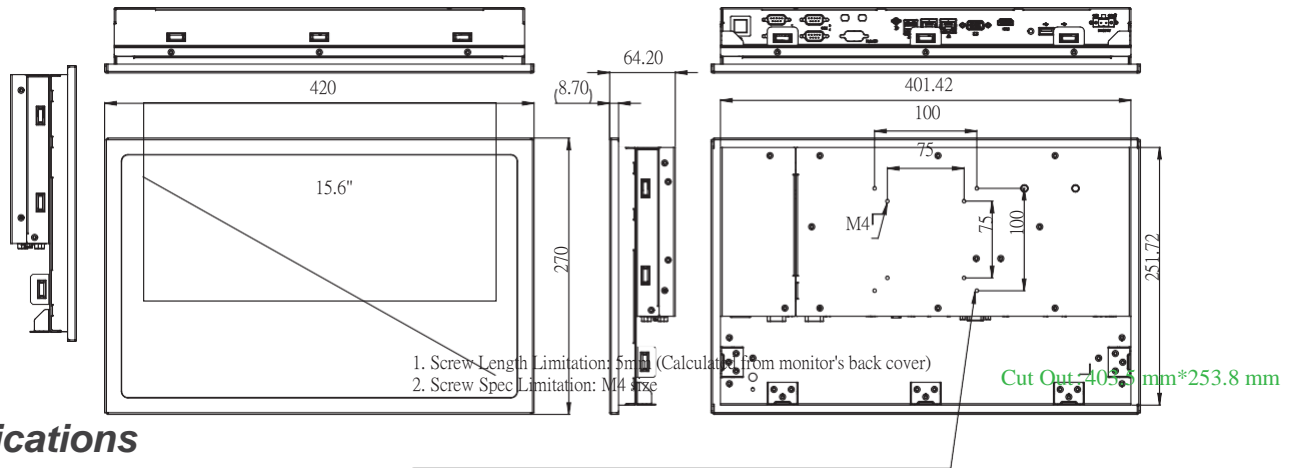

## Specifications

Model		GSR-152PW
Processor System	CPU	Intel® Celeron® J1900 Processor
	Frequency	Quad-Core up to 2.0 GHz
	L2 Cache	Intel® Smart Cache 2 MB
	System Chipset	N/A
	BIOS	UEFI
Memory	Technology	DDR3L 1333 MHz SDRAM
	Max. Capacity	8 GB
	Socket	1 (204-pin SO-DIMM)
Display	Panel Size	15" LCD Panel
	Resolution	1366 x 768 (HD)
	Viewing Angle	80 x 80 (H) x 80 x 80 (V)
	Brightness	300 (cd/m2)
	Color Support	16.7M
	Contrast Ratio	500:1
	Response Time	3 (msec)
	HDMI	HDMI 1.4a up to 1920 x 1200
	Three Display	LCD Panel+ VGA or LCD Panel+ HDMI
Touchscreen	Touchscreen Type	Projected Capacitive
	Surface Hardness	7 Mohs
	Durability	-
	Transparency	90% (±3%)
I/O Interface	USB	2 USB 3.0, 2 USB2.0
	Serial Port	4 COM (1 RS-232/422/485, 3 RS-232)
	Digital I/O	8-pin Digital I/O (DB-9 connector, Option)
	Expansion	2 Mini PCIe (1 full-size Mini PCIe or mSATA, selected by jumper setting; 1 half-size Mini PCIe)
Ethernet	Controller	Dual GbE, 10/100/1000 Mbps (Realtek RTL8111G-CG)
Audio	Chipset	Realtek ALC662 High Definition Audio (HD)
	Connector	Line out
Storage	mSATA	1 mSATA (shared with full-size mini PCIe)
	SATA II	1 Internal 2.5" HDD/SSD
Power	Power Supply Voltage	Supports 9-36 V DC input
	Connector Type	2-Pin Terminal Block, Phoenix Connector
	Power Consumption (Typical)	1.53 A @ 12 V (18.4 W)
	Power Consumption (Max.)	1.8 A @ 12 V (21.6 W)
Environment	Battery	Lithium 3 V / 210 mAH
	Operating Temperature	0~50° C (32~122° F) (Humidity: 50° C @ 80% RHNon- condensing) w/ 2.5" Extended Temp. SSD
	Storage Temperature	-40~85° C (-40~185° F) (Humidity: 85° C @ 80% RHNon- condensing)
	Humidity	5~95% @ 40° C, non-condensing
	Vibration	5-500 Hz, 0.026 G <sup>2</sup> /Hz, 2.16 Grms, X, Y, Z, 1 hour per axis
General	Certification	TBD
	Ingress Protection	IP54
	Dimensions (L x W x H)	420 x 270 x 64.2 mm (16.54" x 10.63" x 2.53")
	Weight	7.5 kg
Operating System	Windows 7/8.1/10, WES7-E/P, WE8S, Ubuntu 14.04	